

DATI®-BESCHREIBUNG DATI®-DESCRIPTION

- Hülse mit Kennzeichnung
- Stelleinsatz mit Anzeigepfeil. Der vertiefte Anzeigepfeil dient als Schraubslot zur Einstellung und zum Einsatzwechsel
- Befestigungsgewinde
- Druckfeder zum stufenlosen Arretieren des Stelleinsatzes
- Werkstoff für Hülse und Stelleinsatz: 1.4034, gehärtet HRC 56 ± 2 rostfrei
- Beschriftung spiegelbildlich

- Sleeve with identifier
- Adjustable insert with an indicator arrow. The recessed indicator arrow is used as a screw slot for adjustment and to change the insert
- Fastening thread
- Compression spring for the infinite locking of the adjustable insert
- Material for sleeve and adjustable insert: 1.4034, hardened HRC 56 ± 2 stainless
- Inscription: laterally reversed

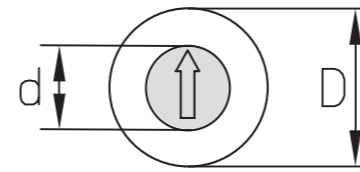
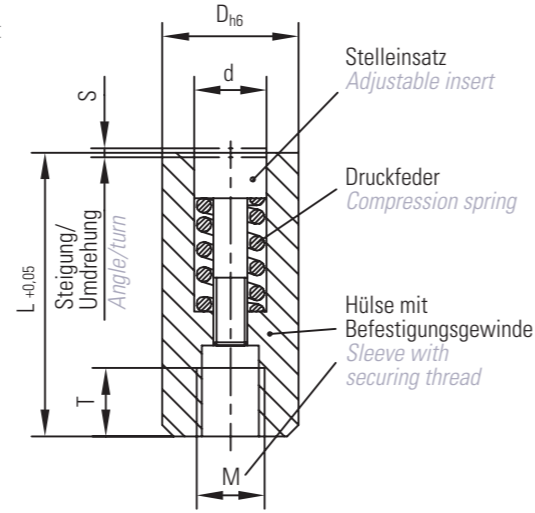

Maßtabelle in mm Dimension table in mm									
D	3	4	5	6	8	10	12	16	mm
d	1,6	2,5	3,1	3,1	4,6	4,6	6,4	8,4	mm
L	14	14	17	17	20	20	25	33	mm
M	2	2	3	3	4	5	6	8	mm

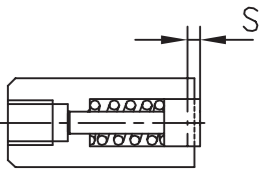

Montage Installation

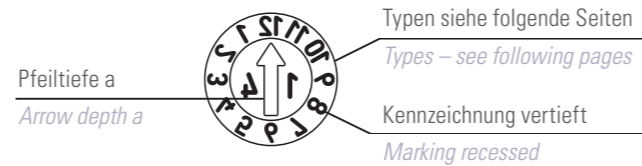
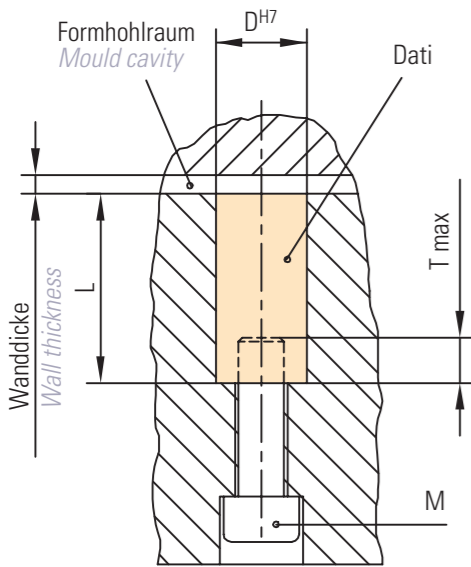

Maßtabelle in mm Dimension table in mm						
D	d	L	M	T	a	S
3	1,6	14	2	3	0,20	0,25
4	2,5	14	2	3	0,30	0,20
5	3,1	17	3	3	0,40	0,20
6	3,1	17	3	3	0,40	0,20
8	4,6	20	4	4	0,40	0,35
10	4,6	20	5	4	0,40	0,35
12	6,4	25	6	6	0,60	0,50
16	8,4	33	8	8	0,60	0,60

SCHNELLWECHSELSYSTEM FAST CHANGING SYSTEM

			<p>Der Stelleinsatz mit Jahreszahl wird zum Jahreswechsel durch Aus- und Eindrehen in Sekunden schnelle gewechselt.</p> <ul style="list-style-type: none"> - Fertigung unterbrechen, Form öffnen - Stelleinsatz wechseln, Zeitraum einstellen - Fertigung fortsetzen - Kontrolle der Einstellung am Spritzteil <p>At the end of each year, the adjustable insert with year is changed in a matter of seconds by removing and screwing it in.</p> <ul style="list-style-type: none"> - Stop production, open mould - Change adjustable insert, set date - Continue production - Check setting on moulded part
<p>Stelleinsatz eindrehen:</p> <ul style="list-style-type: none"> • Rechts drehen • Nach Augenmaß auf Höhe einstellen <p>To screw in adjustable insert:</p> <ul style="list-style-type: none"> • Turn clockwise • Adjust height according to visual estimate 	<p>Stelleinsatz verdrehen:</p> <ul style="list-style-type: none"> • Rechts oder links einstellen • Auf Höhenverstellung achten <p>To turn adjustable insert:</p> <ul style="list-style-type: none"> • Turn clockwise or counter-clockwise • Check height adjustment 	<p>Stelleinsatz wechseln:</p> <ul style="list-style-type: none"> • Kontinuierlich nach links drehen • Stelleinsatz hebt sich • Stelleinsatz entnehmen <p>To change adjustable insert:</p> <ul style="list-style-type: none"> • Turn continuously counter-clockwise • The adjustable insert will raise • Remove adjustable insert 	

Typ Type	A	B	C	CC				
Anzeige Indicator	Monate + Jahr (z. B. Dez. 14) <i>Months + year (e.g. dec. 14)</i>	Monate (z. B. Dez.) kombinierbar mit Typ C (zeigt z. B. Dez. 14) <i>Months (e.g. dec.) connected with type C (displays e.g. dec. 14)</i>	Jahr + 5 Jahre kombinierbar mit Typ B (zeigt z. B. Dez. 14) <i>Year + 5 years connected with type B (displays e.g. dec. 14)</i>	Jahr + 11 Jahre kombinierbar mit Typ B (zeigt z. B. Dez. 14) <i>Year + 11 years connected with type B (displays e.g. dec. 14)</i>				
D	Bestell-Nr. Order no.	Euro	Bestell-Nr. Order no.	Euro	Bestell-Nr. Order no.	Euro	Bestell-Nr. Order no.	Euro
3	A/3/Jahr(Year)	25,00	B/3/00	25,00	C/3/Jahr(Year)+5	25,00	CC/3/Jahr(Year)+11	25,00
4	A/4/Jahr(Year)	25,00	B/4/00	25,00	C/4/Jahr(Year)+5	25,00	CC/4/Jahr(Year)+11	25,00
5	A/5/Jahr(Year)	25,00	B/5/00	25,00	C/5/Jahr(Year)+5	25,00	CC/5/Jahr(Year)+11	25,00
6	A/6/Jahr(Year)	25,00	B/6/00	25,00	C/6/Jahr(Year)+5	25,00	CC/6/Jahr(Year)+11	25,00
8	A/8/Jahr(Year)	25,00	B/8/00	25,00	C/8/Jahr(Year)+5	25,00	CC/8/Jahr(Year)+11	25,00
10	A/10/Jahr(Year)	25,00	B/10/00	25,00	C/10/Jahr(Year)+5	25,00	CC/10/Jahr(Year)+11	25,00
12	A/12/Jahr(Year)	27,00	B/12/00	27,00	C/12/Jahr(Year)+5	27,00	CC/12/Jahr(Year)+11	27,00
16	A/16/Jahr(Year)	27,00	B/16/00	27,00	C/16/Jahr(Year)+5	27,00	CC/16/Jahr(Year)+11	27,00

Typ Type	D + E	H + I	L + E	J				
Anzeige Indicator	Woche + Jahr (z. B. ergibt die Kombination aus den Zahlen 30 + 5: Kw 35/14) <i>Week + year (e.g. the combination of the numbers 30 and 5 results in 30 + 5: calendar week 35/14)</i>	Tage (z. B. 20 + 9 = 29) kombinierbar mit Typ A (zeigt z. B. 29. Dez. 14) <i>Days (e.g. 20 + 9 = 29) connected with type A (displays e.g. 29. dec. 14)</i>	Tage + Monat + Jahr (z. B. 25. Mai 14) <i>Days + month + year (e.g. 25. may 14)</i>	Schichtzahlen (z. B. 2. Schicht) <i>Shift numbers (e.g. 2nd shift)</i>				
D	Bestell-Nr. Order no.	Euro	Bestell-Nr. Order no.	Euro	Bestell-Nr. Order no.	Euro	Bestell-Nr. Order no.	Euro
3	D+E/3/Jahr(Year)	50,00	H+I/3/00	50,00	L+E/3/Jahr(Year)	94,00	J/3/00	25,00
4	D+E/4/Jahr(Year)	50,00	H+I/4/00	50,00	L+E/4/Jahr(Year)	94,00	J/4/00	25,00
5	D+E/5/Jahr(Year)	50,00	H+I/5/00	50,00	L+E/5/Jahr(Year)	94,00	J/5/00	25,00
6	D+E/6/Jahr(Year)	50,00	H+I/6/00	50,00	L+E/6/Jahr(Year)	94,00	J/6/00	25,00
8	D+E/8/Jahr(Year)	50,00	H+I/8/00	50,00	L+E/8/Jahr(Year)	94,00	J/8/00	25,00
10	D+E/10/Jahr(Year)	50,00	H+I/10/00	50,00	L+E/10/Jahr(Year)	94,00	J/10/00	25,00
12	D+E/12/Jahr(Year)	54,00	H+I/12/00	54,00	L+E/12/Jahr(Year)	120,00	J/12/00	27,00
16	D+E/16/Jahr(Year)	54,00	H+I/16/00	54,00	L+E/16/Jahr(Year)	120,00	J/16/00	27,00

Typ Type	K		M		N		R	
Anzeige Indicator	Quartal + Jahr (z. B. 1. Quartal 14) <i>Quarter + year (e.g. 1st quarter 14)</i>		Kennbuchstaben A – M (Typ M) <i>Identifier letters A – M (type M)</i>		Kennbuchstaben N – Z (Typ N) <i>Identifier letters N – Z (type N)</i>		Kennzeichnung nach Wunsch z. B. Materialkennzeichnung <i>Identification according to customers preference e.g. material identification</i>	
D	Bestell-Nr. Order no.	Euro	Bestell-Nr. Order no.	Euro	Bestell-Nr. Order no.	Euro	Bestell-Nr. Order no.	Euro
3	K/3/Jahr(Year)	25,00	M/3/00	25,00	N/3/00	25,00	R/3/Zeichen(Symbol)	30,00
4	K/4/Jahr(Year)	25,00	M/4/00	25,00	N/4/00	25,00	R/4/Zeichen(Symbol)	30,00
5	K/5/Jahr(Year)	25,00	M/5/00	25,00	N/5/00	25,00	R/5/Zeichen(Symbol)	30,00
6	K/6/Jahr(Year)	25,00	M/6/00	25,00	N/6/00	25,00	R/6/Zeichen(Symbol)	30,00
8	K/8/Jahr(Year)	25,00	M/8/00	25,00	N/8/00	25,00	R/8/Zeichen(Symbol)	30,00
10	K/10/Jahr(Year)	25,00	M/10/00	25,00	N/10/00	25,00	R/10/Zeichen(Symbol)	30,00
12	K/12/Jahr(Year)	27,00	M/12/00	27,00	N/12/00	27,00	R/12/Zeichen(Symbol)	32,00
16	K/16/Jahr(Year)	27,00	M/16/00	27,00	N/16/00	27,00	R/16/Zeichen(Symbol)	32,00

Typ Type	T		WT		Z	
Anzeige Indicator	Tage 1 – 31 <i>Days 1 – 31</i>		Wochentage 1 – 7 <i>Weekdays 1 – 7</i>		ohne Kennzeichnung <i>without markings</i>	
D	Bestell-Nr. Order no.	Euro	Bestell-Nr. Order no.	Euro	Bestell-Nr. Order no.	Euro
3	T/3/00	25,00	WT/3/00	25,00	Z/3/00	17,00
4	T/4/00	25,00	WT/4/00	25,00	Z/4/00	17,00
5	T/5/00	25,00	WT/5/00	25,00	Z/5/00	17,00
6	T/6/00	25,00	WT/6/00	25,00	Z/6/00	17,00
8	T/8/00	25,00	WT/8/00	25,00	Z/8/00	17,00
10	T/10/00	25,00	WT/10/00	25,00	Z/10/00	17,00
12	T/12/00	27,00	WT/12/00	27,00	Z/12/00	20,00
16	T/16/00	27,00	WT/16/00	27,00	Z/16/00	20,00

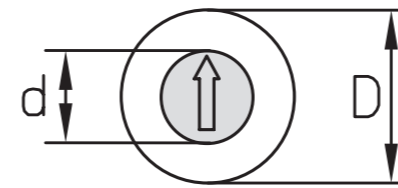

! Stelleinsätze werden auf Wunsch mit Druckfeder geliefert!
Adjustable insert will be delivered with compression spring on request!

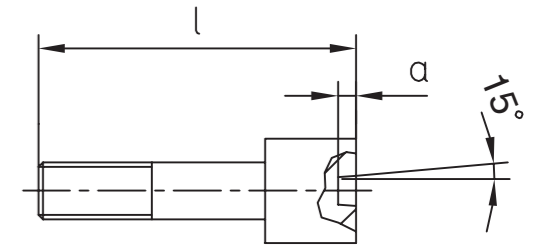

Werkstoff:
1.4034, gehärtet HRC 56 ± 2 rostfrei

Material:
1.4034, hardened HRC 56 ± 2 stainless

Maßtabelle in mm Dimension table in mm									
D	3	4	5	6	8	10	12	16	mm
d	1,6	2,5	3,1	3,1	4,6	4,6	6,4	8,4	mm
L	9	10,5	13	13	14	14	17	23	mm
a	0,2	0,30	0,40	0,40	0,40	0,40	0,60	0,60	mm

Stelleinsätze für DATI 1000 Adjustable inserts for DATI 1000

Typ Type	F		G		O	
Anzeige Indicator	Stelleinsatz mit Pfeil + Jahr <i>Adjustable inserts with arrow + year</i>		Stelleinsatz mit Pfeil ohne Jahr <i>Adjustable inserts with arrow without year</i>		Stelleinsatz nach Kundenwunsch mit Zahlen und / oder Buchstaben <i>Adjustable inserts according to customer preference with numbers and / or letters</i>	
D	Bestell-Nr. Order no.	Euro	Bestell-Nr. Order no.	Euro	Bestell-Nr. Order no.	Euro
3	F/3/Jahr(Year)	8,50	G/3/00	8,50	O/3/Zeichen(Symbol)	11,00
4	F/4/Jahr(Year)	8,50	G/4/00	8,50	O/4/Zeichen(Symbol)	11,00
5	F/5/Jahr(Year)	8,50	G/5/00	8,50	O/5/Zeichen(Symbol)	11,00
6	F/6/Jahr(Year)	8,50	G/6/00	8,50	O/6/Zeichen(Symbol)	11,00
8	F/8/Jahr(Year)	8,50	G/8/00	8,50	O/8/Zeichen(Symbol)	11,00
10	F/10/Jahr(Year)	8,50	G/10/00	8,50	O/10/Zeichen(Symbol)	11,00
12	F/12/Jahr(Year)	9,50	G/12/00	9,50	O/12/Zeichen(Symbol)	14,00
16	F/16/Jahr(Year)	9,50	G/16/00	9,50	O/16/Zeichen(Symbol)	14,00



Einbau in Formkavität *Installation in mould cavity*

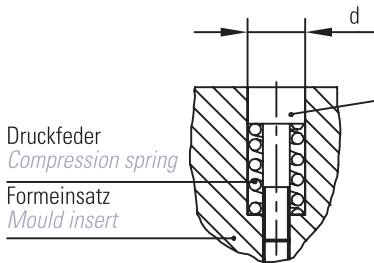

Stelleinsatz mit Druckfeder Seite 13
 Adjustable inserts with compression spring page 13

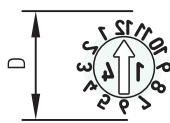

Erodierbild spiegelbildlich
 Eroding image literally reversed

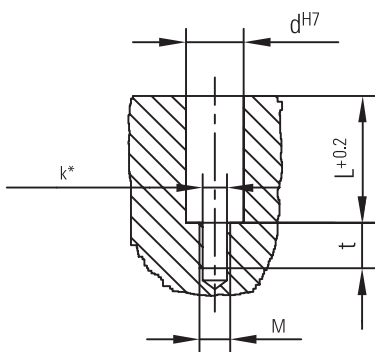

* k = Kernlochbohrung * k = core drilling

Einbau in Auswerferstift *Installation in ejector pin*

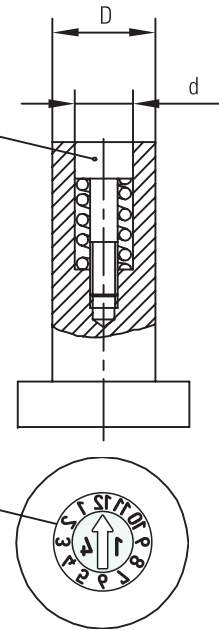

Maßtabelle in mm <i>Dimension table in mm</i>					
D	d	L	k	M	t
4	2,5	6,7	1,2	1,4 x 0,2	4
5	3,1	9,5	1,4	1,6 x 0,2	4
6	3,1	9,5	1,4	1,6 x 0,2	4
8	4,6	11	2,1	2,5 x 0,35	6
10	4,6	11	2,1	2,5 x 0,35	6
12	6,4	14	2,5	3,0	7
16	8,4	18	2,9	3,5	10

Elektrode *Electrode*

Gravurbild gem. Dati Typenliste
 Typ A – Z

Beispiel Typ A



Engraving image acc. to Dati type list
 type A – Z

Example type A

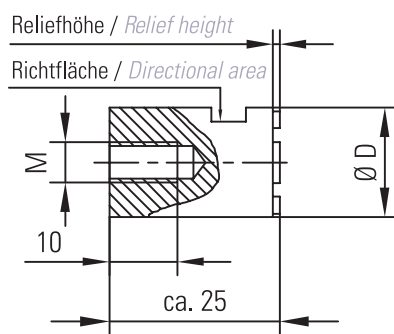

Maßtabelle in mm <i>Dimension table in mm</i>			
D	M	Reliefhöhe <i>relief height</i>	Euro
4	2	0,5	35,00
5	3	0,5	35,00
6	4	0,5	35,00
8	4	0,5	35,00
10	4	0,5	35,00
12	6	1,0	39,00
16	6	1,0	39,00

Bestellbeispiel: Elektrode Ø 6 mit Monaten 1 – 12 gemäß Typenliste: 1-A-6
 Ordering: electrode Ø 6 with months 1 – 12 acc. to type list: 1-A-6

Material: Erodierkupfer
 Material: copper

Gewindebohrer HSSE *Cutting tap HSSE*

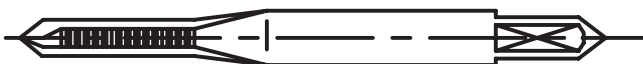

Maßtabelle in mm <i>Dimension table in mm</i>	
M	Euro
1,6 x 0,2	62,00
2,5 x 0,35	35,00
3,0	25,00
3,5	25,00